

SAled[®]

A U S T R A L I A

SAled LIGHTING
LED CANOPY LIGHT



PRODUCT FEATURE

- High Efficiency 130 lm/watt.
- Instant start, no noise, no flickering.
- Light weight, Compact design, Easy Installation.
- Surface mount, recessed mount installation available.
- Suitable for LED industry lighting.
- 5 Year warranty.



SPECIFICATION

- Power : 150W
- Efficiency : 130lm/W
- Luminous Flux : >19,500lm
- Input Voltage : AC100V-240V
- Power Factor : >0.90
- CCT : 6500K
- Beam Angle : 110°
- IP Rating : IP65
- CRI : Ra > 70
- Lumen Maintenance : >50,000 hours
- Operation Temperature: -30 °C - +50 °C

TYPE OF INSTALLATION

- Surface Mount Type



Item Code : SL 91111
Model : LED Canopy Light
Power : 150W

- Recessed Type



Item Code : SL 91211
Model : LED Canopy Light
Power : 150W

I APPLICATIONS

- Service Stations, Carparks, Covered walkway, Airport, Train Station, Shopping mall, etc.



I DIMENSIONS(mm)

- Surface Mount Type

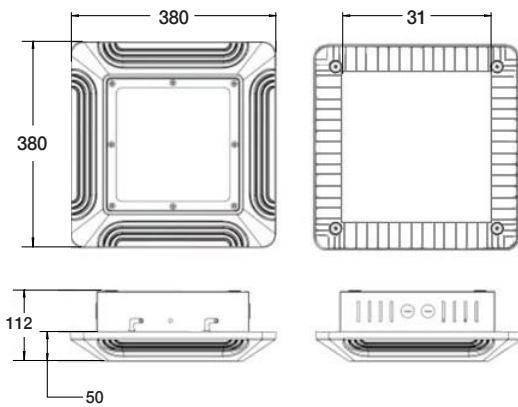

- Recessed Type

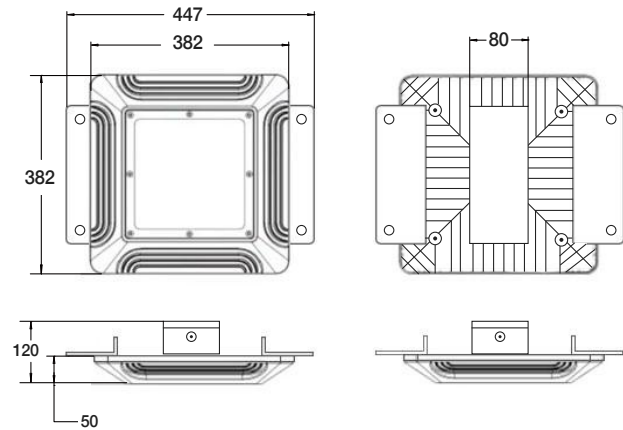

Size : mm

ITEM CODE	TYPE	WIDTH	DEPTH	HEIGHT	WEIGHT(KG)
SL 91111	Surface Mount Type	380	380	112	7.8Kg
SL 91211	Recessed Type	447	382	120	6.95Kg

I PHOTOMETRY

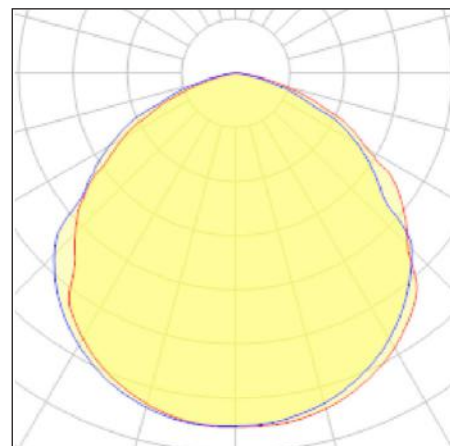
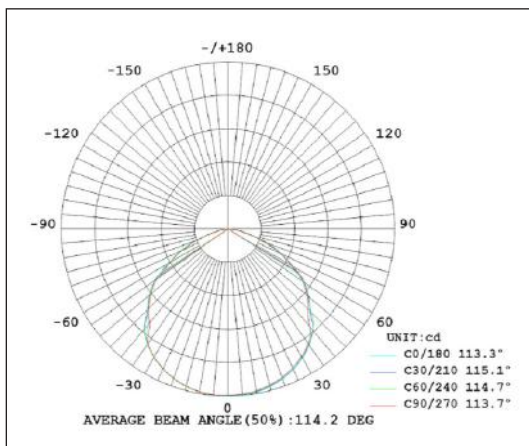

110°